

**LUBRICATION  
ORDER**

**L05-4310-335-12  
28 OCTOBER 1968**

**COMPRESSOR, RECIPROCATING AIR, WHEEL MOUNTED, 2 WHEEL,  
PNEUMATIC TIRES, G.E.D. 4 CFM, 3000 PSI,  
(WALTER KIDDE MODEL 893811)**

Reference: L05-2805-257-12, and C9100-IL

Intervals are based on normal hours of operation. Adjust to compensate for abnormal operation and severe conditions. During inactive periods, sufficient lubrication must be performed for adequate preservation.

Clean fittings before lubricating.

Relubricate after washing.

Clean parts with SOLVENT, dry-cleaning, or with OIL, fuel, Diesel. Dry before lubricating.

Lubricate points indicated by dotted arrow shafts on both sides of equipment.

Drain crankcase when hot. Fill and check level.

LUBRICANT ● INTERVAL

INTERVAL ● LUBRICANT

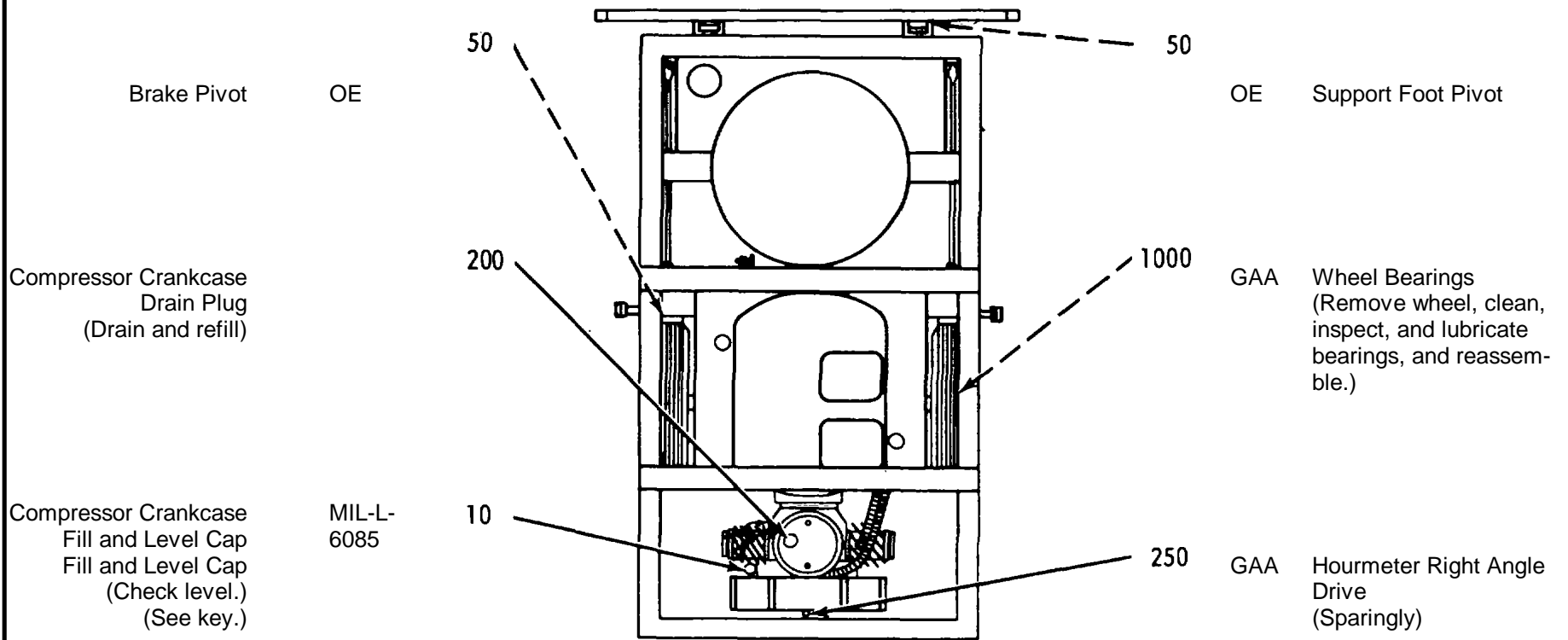

-KEY-

LUBRICANTS	CAPACITY	ALL TEMPERATURES	INTERVALS
OE-OIL, Engine, Heavy Duty		OE 30	Intervals given are in hours of normal operation.
Oil Can Points			
MIL-L-6085-LUBRICATING OIL		FSN 9150-753-4667	
Compressor crankcase	3/4 pt		
GAA-GREASE Automotive & Artillery			

NOTE:

1. LUBRICANTS. The following is a list of lubricants with the Military Symbols and applicable Specification numbers.

OE-MIL-L-2104  
OAI-MIL-L-6085

GAA-MIL-G-10924

2. OIL CAN POINTS. Every 50 hours lubricate brake pivot points, support foot pivot, control linkage and all exposed adjusting threads with OE.

Copy of this Lubrication Order will remain with the equipment at all times; instructions contained herein are mandatory.

BY ORDER OF THE SECRETARY OF THE ARMY:

W. C. WESTMORELAND  
General, United States Army,  
Chief of Staff.

OFFICIAL:

KENNETH G. WICKHAM,  
Major General, United States Army,  
The Adjutant General.

LO 5-4310-335-12 DISTRIBUTION: To be distributed in accordance with DA Form 12-25  
Section I, (qty rqr block no. 2) organizational maintenance requirements for Air Compressors,  
under 5 CFM.

RECOMMENDED CHANGES TO EQUIPMENT TECHNICAL PUBLICATIONS



*THEN...JOT DOWN THE  
DOPE ABOUT IT ON THIS FORM.  
CAREFULLY TEAR IT OUT, FOLD IT  
AND DROP IT IN THE MAIL.*

**SOMETHING WRONG WITH PUBLICATION**

FROM: (PRINT YOUR UNIT'S COMPLETE ADDRESS)

DATE SENT

PUBLICATION NUMBER

PUBLICATION DATE

PUBLICATION TITLE

BE EXACT PIN-POINT WHERE IT IS

PAGE  
NO.

PARA-  
GRAPH

FIGURE  
NO.

TABLE  
NO.

IN THIS SPACE, TELL WHAT IS WRONG  
AND WHAT SHOULD BE DONE ABOUT IT.

PRINTED NAME, GRADE OR TITLE AND TELEPHONE NUMBER

SIGN HERE

